

# specifications

## FDM900r

SKOPE Food Display Cabinet  
REMOTE Type: F0921

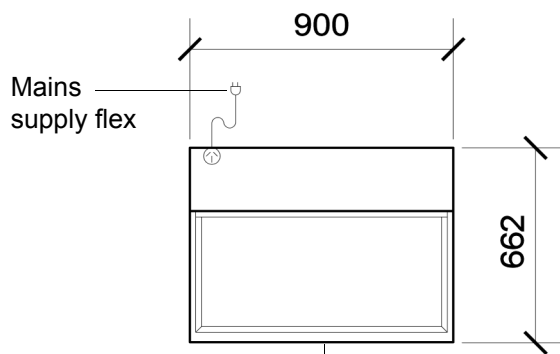

Glass front, sides and top

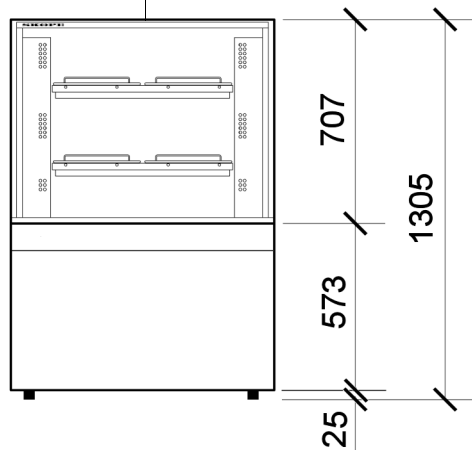

### CABINET DIMENSIONS

	External	Internal
<b>Height:</b>	1305mm	800mm
<b>Width:</b>	900mm	600mm
<b>Depth:</b>	662mm	600mm
<b>Floor area:</b>	0.60m <sup>2</sup>	

Sliding glass rear doors

Adjustable angle shelves

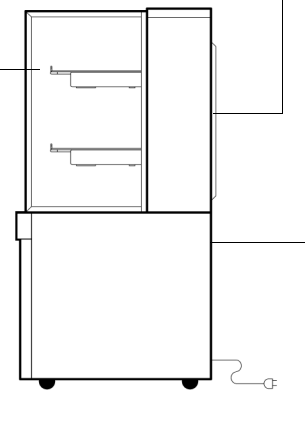

Electronic controller display with unit and lighting on/off switches

Copyright © 2007 SKOPE Industries Limited

### CABINET SPECIFICATIONS

<b>Refrigeration system:</b>	Remote Food Display Refrigeration Unit with electronic controller
<b>Refrigerant:</b>	R134a / R404A
<b>Pipe connection size:</b>	Liquid line: 1/4". Suction line: 3/8"
<b>Remote refrigeration duty:</b>	450 Watts
<b>Cabinet internal volume:</b>	288 litres
<b>Insulation:</b>	50mm polyurethane foam
<b>Cabinet temperature range:</b>	+1° C to +7° C in 32° ambient
<b>Drainage:</b>	Plumbing required
<b>Electrical:</b>	220-240 Volts a.c. 50 Hz, single phase supply, 0.5 Amp
<b>Internal lighting:</b>	3 x 14 Watt T5 fluorescent tubes (Ø16mm x 550mm) Daylight 860
<b>Rear doors:</b>	2 double-glazed sliding doors with internal mirror finish
<b>Internal door opening size:</b>	2 rear door openings: 275mm wide x 630mm high
<b>Shelves:</b>	3 shelves (2 adjustable angle): 630mm wide x 440mm deep
<b>Total weight:</b>	110 kg

SKOPE Industries Limited reserve the right to alter specifications without notice.

PSS0167 Rev 3.1 Apr. 2016



**SKOPE INDUSTRIES LIMITED**



New Zealand Freephone: 0800 947 5673, Fax: (03) 983 3896. Australian Freephone: 1800 121 535, Freefax: 1800 121 533

Email: enquiry@skope.co.nz Website: www.skope.co.nz