

# specifications

## HB80-2 (HB80:JAL)

Counter Top Chiller

Part No: HSC80JAL (R600a)

CABINET DIMENSIONS		
	External	Internal
<b>Height</b>	770mm	630/420mm
<b>Width</b>	500mm	410mm
<b>Depth</b>	560mm	400/250mm
<b>Floor area</b>	0.28m <sup>2</sup>	
<b>Insulation</b>	35/70mm polyurethane foam	

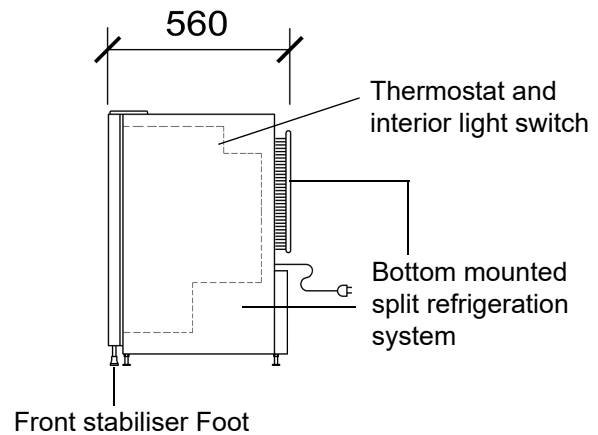
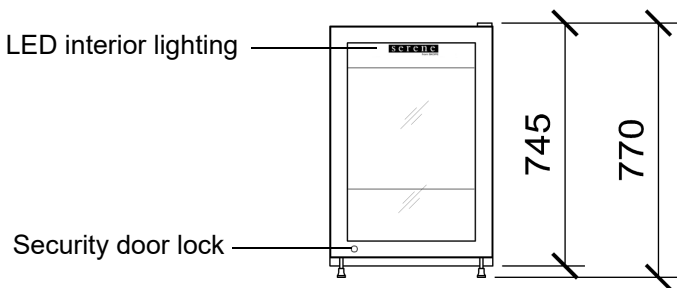
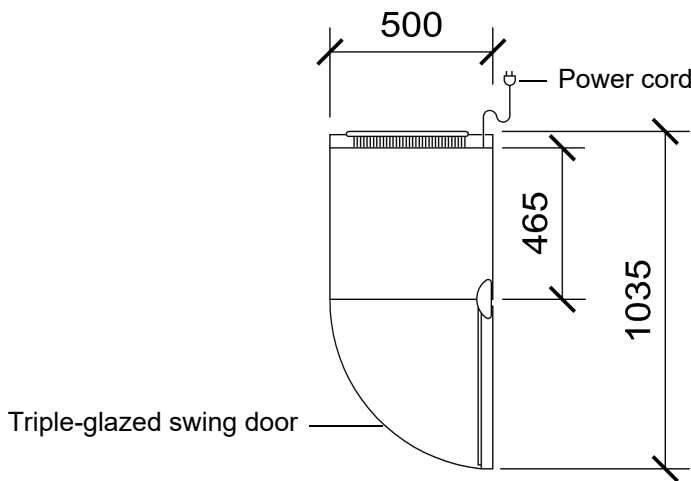

### CABINET SPECIFICATIONS

<b>Refrigeration system</b>	Bottom mounted split refrigeration system, with adjustable thermostat
<b>Refrigerant</b>	R600a / 26 grams
<b>Nominal capacity</b>	190 Watts
<b>Cabinet internal volume</b>	80 litres
<b>Cabinet temperature range</b>	1°C to 4°C
<b>Drainage</b>	No plumbing required
<b>Supply</b>	220-240 Volts a.c. 50 Hz
<b>Rated Current</b>	0.9 Amp
<b>Interior lighting</b>	1 × 4W LED light (switched) located in cabinet ceiling
<b>Power cord</b>	2.0m flexible power cord with 3-pin plug
<b>Door</b>	Right-hand hinged (non-reversible), with triple glazed, single Low-E, argon filled safety-glass
<b>Door opening size</b>	1 door opening 630mm high x 410mm wide
<b>Shelves</b>	2 white plastic coated wire shelves 405mm wide x 360mm deep
<b>Total weight</b>	38 kg

Copyright © 2006 SKOPE Industries Limited  
SKOPE Industries Limited reserve the right to alter specifications without notice.

PSS0496 Rev. 1.2 Dec. 2021