

specifications

SC112

serene

from SKOPE

SERENE Four Glass Sided Chiller

Type: HSC112A/Z089S

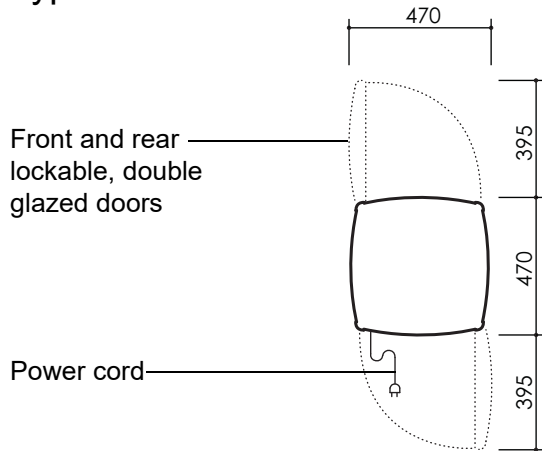

CABINET DIMENSIONS

	External	Internal
Height:	1080-1095mm	740mm
Width:	470mm	340mm
Depth:	470mm	350mm
Floor area:	0.22m ²	

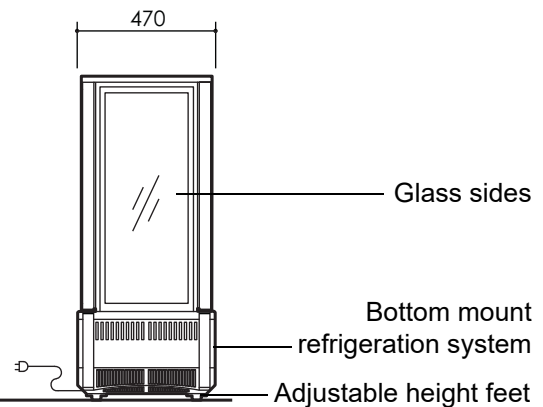
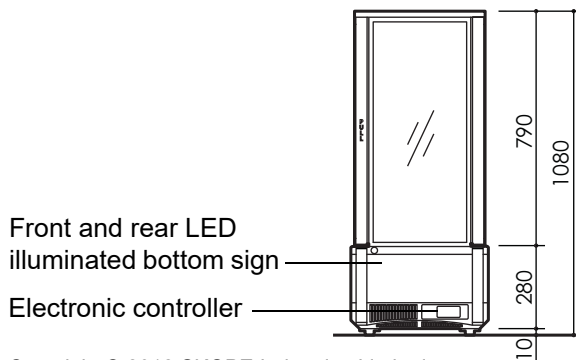

Copyright © 2012 SKOPE Industries Limited

CABINET SPECIFICATIONS

Refrigeration system:	Bottom mounted, integral, electronically controlled refrigeration system
Electronic controller:	CAREL Eco Box
Refrigerant:	R134a / 135g
Nominal capacity:	235 Watts (@ -15°C SST) CECOMAF rating condition
Cabinet internal volume:	109 litres
Cabinet temperature range:	+1°C to +4°C
Drainage:	No plumbing required
Tested climate:	25°C @ 60% RH (climatic class 3)
Electrical:	220-240 Volts a.c. 50 Hz, single phase supply, 1.2 Amps
Internal lighting:	4 x vertical corner LED lights (total 8W)
Sign lighting:	2 x horizontal bottom sign LED lights (total 2W)
Internal door opening size:	2 x door openings: 338mm wide x 730mm high
Doors:	2 x double glazed, single Low-E, lockable, toughened glass swing doors (RH hinged)
Shelves:	3 x adjustable height wire shelves (351mm x 357mm)
Total weight:	55 kg

SKOPE Industries Limited reserve the right to alter specifications without notice.

PSS0285 Rev. 1.2 Nov. 2016



SKOPE INDUSTRIES LIMITED



New Zealand Freephone: 0800 947 5673, Fax: (03) 983 3896. Australian Freephone: 1800 121 535, Freefax: 1800 121 533

Email: enquiry@skope.co.nz Website: www.skope.co.nz